

## Work Station Jib Cranes

*The safe, productive, ergonomic materials handling solution for servicing a circular area.*



Capacities from 100 to 2,000 lb.

200° Rotation Column or Wall Mounted

360° Rotation Floor Mounted

Steel & Aluminum Enclosed Track Design

Supports Tools, Air Balancers & Hoists

## Work Station Jib Cranes

*Versatile enough to perform a wide variety of local handling and positioning functions. Economical enough to be dedicated to individual work stations.*

Gorbel Work Station Jib Cranes provide excellent coverage in circular areas not efficiently served by a main crane. They're ideal for supporting tool balancers, air balancers, hoists, vacuum lifters and welding wire feeders. And they can handle up to 200° rotation when column or wall mounted, and up to 360° rotation when floor mounted.

Gorbel Work Station Jib Cranes increase productivity through easy boom rotation and trolley movement—thus providing a rapid return on investment. They also reduce injuries and improve safety, since only a low force is required to start and stop the boom rotation and hoist trolley.

When you choose Gorbel Work Station Jib Cranes, you also get quick, reliable delivery, and the industry's best warranty.

***Ergonomic design makes for superior ease of movement, rotation, and positioning***

### Easy Movement

Gorbel Work Station Jib Cranes are easier to move and position than traditional I-beam jibs. The cold-formed, high-strength enclosed track design keeps rolling surfaces clean, which contributes to easier movement and longer life. The track's low weight-per-foot reduces the dead weight of the boom. And all Gorbel enclosed track profiles feature a 2° taper in the lower running flange, which helps center the trolley within the track. This increases wheel life and allows smooth rolling of the trolleys.

### Unsurpassed Ease of Rotation

The steel enclosed track free standing and wall mounted work station jibs (WSJ360 and WSJ200) weigh less and rotate easier than traditional I-beam cranes. The aluminum wall mounted jibs (AL100) feature extruded aluminum enclosed track that is lighter in weight for even easier movement of the boom. The low swing weight of the boom assembly and precision tapered roller pivot bearings (WSJ360 and WSJ200) or bronze bushings with oilite thrust washers (AL100) combine to produce effortless rotation.

### Precise Load Positioning

A hoist trolley with low rolling resistance and lubricated-for-life sealed bearings combined with the easy rotation of the boom make Gorbel Work Station Jib Cranes *A Class Above* when it comes to positioning and spotting loads.

### DURACOMP 4™ Wheels Operate Quietly and Withstand Wear and Tear

Gorbel trolley wheels are made of DURACOMP 4™—a food grade material that outperforms steel wheels in endurance and destructive testing. Wheels are tapered to match the track flange's 2° taper, which enhances wheel life and keeps the trolleys running smoothly. Trolleys are designed to operate in temperatures from 5°F to 200°F.

### Pre-engineered for Powered Hoists

Hoist trolleys are included in the base price of all Gorbel Work Station Jib Cranes. A factor of 15% of the jib capacity is allowed for the weight of the hoist, trolley, and below-the-hook device. A factor of 25% of the jib capacity is allowed for impact (covers hoist speeds up to 50 f.p.m.). Custom designs are available for applications in which it is necessary to exceed these factors.

### Thrust and Pull Requirements

All WSJ200 or AL100 Jib Cranes require a structurally adequate wall or column to support the jib. Refer to the "thrust & pull" forces on the following pages to determine the forces that your structural support must resist to properly support the jib.

***Gorbel Work Station Jib Cranes are easy to install***

### Wide Variety of Spans and Capacities

Gorbel Work Station Jib Cranes are available in a wide range of spans and capacities to meet a variety of needs without the extra costs and lead time associated with customization.

### Lightweight Components

The light weight of the boom and mast assembly makes installation a breeze.

### Variety of Mounting Styles

Gorbel's Work Station Jib Cranes are available in several mounting styles to meet the needs of your application. The WSJ360 is a free standing jib that provides 360° of rotation and, in many cases, can be mounted on an existing six (6) inch reinforced concrete floor. The WSJ200 (wall or column mounted), with a unique truss design requires minimal overhead clearance for installation. The AL100 aluminum tie rod style jib (wall or column mounted) has less deflection for easier control and positioning, but requires more overhead clearance for installation.



## WSJ360 Free Standing Work Station Jib Cranes

### 360° rotation

In most cases, Gobel WSJ360 Free Standing Series Jib Cranes can be bolted directly to your existing floor without adding special foundations (see the specific product information on the pages that follow for more details). These cranes feature a retaining pin through the pivot pin to help resist accidental upward dislodgment of the boom assembly.



## WSJ200 Wall Cantilever Work Station Jib Cranes

### 200° rotation

The wall or column mounted WSJ200 crane uses tapered roller bearings at the pivot points for unsurpassed ease of rotation. To ensure that the jib is aligned through the pivot axis and thus avoid unwanted drifting of the boom, shim stock up to 7/32" is included with each jib.



## AL100 Wall Bracket Work Station Jib Cranes

### 200° rotation

The AL100 Wall Bracket Work Station Jib Crane utilizes Gobel's patented light weight, high-strength extruded aluminum enclosed track for its boom. This revolutionary new aluminum track reduces the rotational dead weight of the boom by 56% to 68%, allowing the AL100 to rotate up to 40% easier than a comparable I-beam jib. Sufficient clearance throughout the arc of the boom must exist to accommodate the tie rod suspension.

**AL100 WALL BRACKET WORK STATION JIB CRANES: 200° ROTATION**

CAPACITY	SPAN	MODEL NUMBER	TRACK SERIES	WEIGHT	B	D	G	T	TIE ROD DIAMETER	THRUST & PULL
					in	in	in	in		
150#	4'	AL100-G1-150-4	A0250	140#	18	12	7-1/4	2-5/8	1"	511#
	6'	AL100-G1-150-6	A0250	152#	21	15	7-1/4	2-5/8	1"	701#
	8'	AL100-G1-150-8	A0250	165#	24	18	7-1/4	2-5/8	1"	852#
	10'	AL100-G1-150-10	A0250	178#	27	21	7-1/4	2-5/8	1"	976#
	12'	AL100-G1-150-12	A0250	190#	30	24	7-1/4	2-5/8	1"	1,081#
	14'	AL100-G1-150-14	A0250	203#	33	27	7-1/4	2-5/8	1"	1,173#
	16'	AL100-G1-150-16	A0250	216#	36	30	7-1/4	2-5/8	1"	1,256#
	18'	AL100-G1-150-18	A0250	228#	39	33	7-1/4	2-5/8	1"	1,330#
	20'	AL100-G1-150-20	A0250	241#	42	36	7-1/4	2-5/8	1"	1,399#
250#	4'	AL100-G1-250-4	A0250	140#	18	12	7-1/4	2-5/8	1"	838#
	6'	AL100-G1-250-6	A0250	152#	21	15	7-1/4	2-5/8	1"	1,141#
	8'	AL100-G1-250-8	A0250	165#	24	18	7-1/4	2-5/8	1"	1,377#
	10'	AL100-G1-250-10	A0250	178#	27	21	7-1/4	2-5/8	1"	1,567#
	12'	AL100-G1-250-12	A0250	190#	30	24	7-1/4	2-5/8	1"	1,725#
	14'	AL100-G1-250-14	A0250	203#	33	27	7-1/4	2-5/8	1"	1,861#
	16'	AL100-G1-250-16	A0250	216#	36	30	7-1/4	2-5/8	1"	1,979#
	18'	AL100-G1-250-18	A0250	228#	39	33	7-1/4	2-5/8	1"	2,084#
	20'	AL100-G1-250-20	A0250	241#	42	36	7-1/4	2-5/8	1"	2,179#
500#	4'	AL100-G1-500-4	A0500	144#	24	12	7-1/4	2-5/8	1"	1,244#
	6'	AL100-G1-500-6	A0500	158#	30	15	7-1/4	2-5/8	1"	1,574#
	8'	AL100-G1-500-8	A0500	173#	36	18	7-1/4	2-5/8	1"	1,800#
	10'	AL100-G1-500-10	A0500	187#	42	21	7-1/4	2-5/8	1"	1,967#
	12'	AL100-G1-500-12	A0500	202#	48	24	7-1/4	2-5/8	1"	2,097#
	14'	AL100-G1-500-14	A0500	217#	54	27	7-1/4	2-5/8	1"	2,202#
	16'	AL100-G1-500-16	A0500	231#	60	30	7-1/4	2-5/8	1"	2,290#
	18'	AL100-G1-500-18	A0500	244#	69	42	7-1/4	2-5/8	1"	2,263#
	20'	AL100-G1-500-20	A1000	259#	69	42	7-7/8	2-7/8	1"	2,663#
1000#	4'	AL100-G1-1000-4	A1000	160#	24	12	7-7/8	2-7/8	1"	2,483#
	6'	AL100-G1-1000-6	A1000	182#	27	15	7-7/8	2-7/8	1"	3,489#
	8'	AL100-G1-1000-8	A1000	203#	30	18	7-7/8	2-7/8	1"	4,306#
	10'	AL100-G1-1000-10	A1000	225#	33	21	7-7/8	2-7/8	1"	4,987#
	12'	AL100-G1-1000-12	A1000	246#	36	24	7-7/8	2-7/8	1"	5,566#
	14'	AL100-G1-1000-14	A1000	268#	39	27	7-7/8	2-7/8	1"	6,066#
	16'	AL100-G1-1000-16	A1000	289#	42	30	7-7/8	2-7/8	1"	6,504#
	18'	AL100-G1-1000-18	A1000	311#	45	33	7-7/8	2-7/8	1"	6,892#
	20'	AL100-G1-1000-20	A1000	332#	48	36	7-7/8	2-7/8	1"	7,240#
2000#	4'	AL100-G1-2000-4	A2000	182#	36	12	12-7/8	2-7/8	1"	2,827#
	6'	AL100-G1-2000-6	A2000	206#	42	15	12-7/8	2-7/8	1"	4,053#
	8'	AL100-G1-2000-8	A2000	231#	48	18	12-7/8	2-7/8	1"	4,982#
	10'	AL100-G1-2000-10	A2000	256#	54	21	12-7/8	2-7/8	1"	5,713#
	12'	AL100-G1-2000-12	A2000	280#	60	24	12-7/8	2-7/8	1"	6,307#
	14'	AL100-G1-2000-14	A2000	305#	66	27	12-7/8	2-7/8	1"	6,800#
	16'	AL100-G1-2000-16	A2000	330#	75	30	12-7/8	2-7/8	1"	6,929#
18'	AL100-G1-2000-18	A2000	355#	111	45	12-7/8	2-7/8	1"	5,325#	

Note: Dimensions are for reference only and are subject to change without notice.

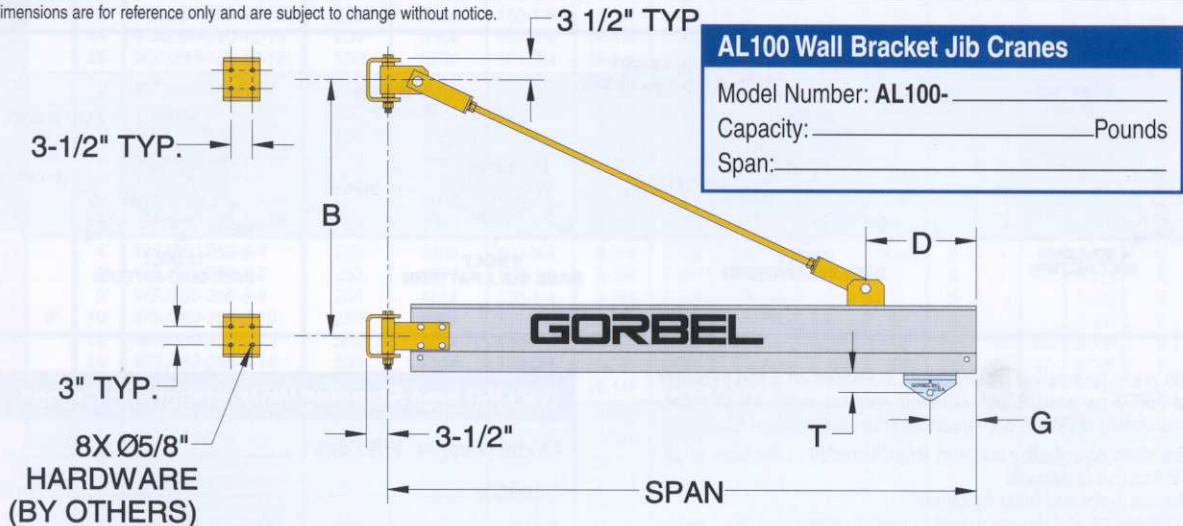

Standard hoist trolley and end stops included in the base price. Festooning is optional. Mounting bolts and hoist by others. Dimensions and design details subject to change without notice.

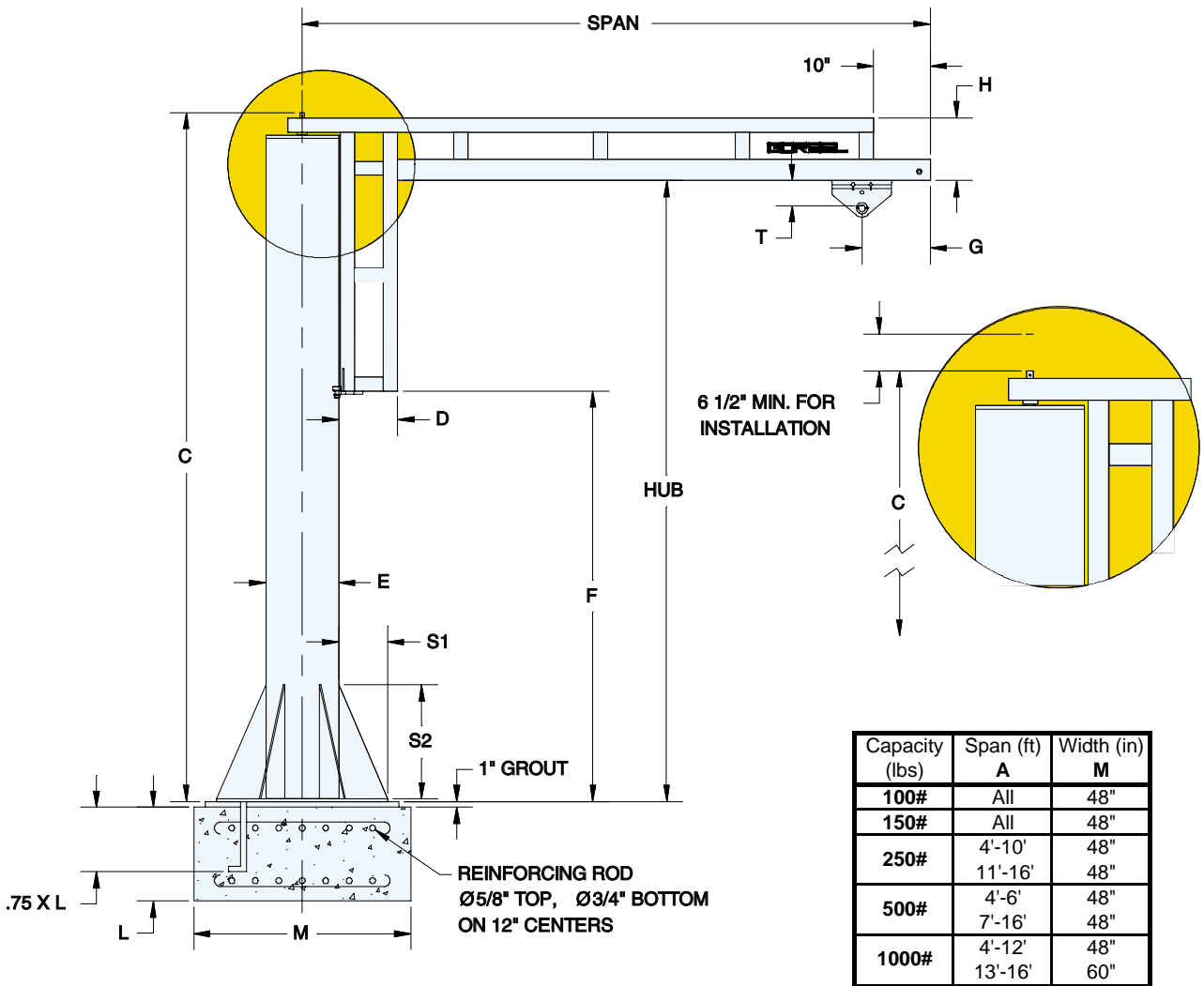

Capacity (lbs)	Span (ft)		Width (in)	
	A	M		
100#	All		48"	
150#	All		48"	
250#	4'-10'		48"	
	11'-16'		48"	
500#	4'-6'		48"	
	7'-16'		48"	
1000#	4'-12'		48"	
	13'-16'		60"	

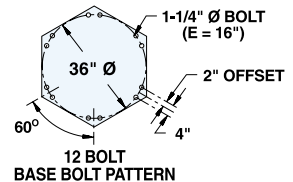
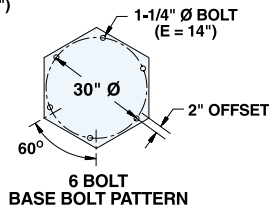
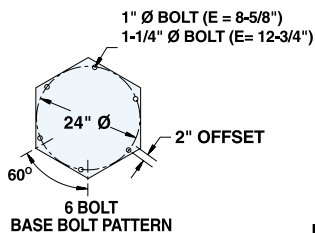
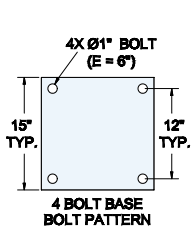

Jib crane foundation requirements are based on a soil pressure of 2500# per square foot. Concrete recommended for jib crane foundation is 3000# per square inch of compressive force.

Standard hoist trolley and end stops included in the base price. Festooning is optional.

Anchor bolts and hoist by others.

Dimensions and design details subject to change without notice.

Existing floor should have no cracks or seams within a 48" square area around center of mast.

**WSJ360 Free Standing Work Station Jib Cranes**

Model Number: **WSJ360-** \_\_\_\_\_

Capacity: \_\_\_\_\_ Pounds

Span: \_\_\_\_\_ Hub: \_\_\_\_\_

**WSJ360 FREE STANDING WORK STATION JIB CRANES: 360° ROTATION**

CAPACITY	HUB	SPAN	MODEL NUMBER	TRACK SERIES	WEIGHT	C	D	E	F	G	H	L	S1	S2	T	BOLT QTY.	ANCHOR BOLT LOAD
						in	in	in	in	in	in	in	in	in	in		
<b>100#</b>	8'	4'	WSJ360-100-8-4	250	340#	103-3/4	9-3/4	6-5/8	69-1/8	5	4-1/4	6	-	-	1-1/2	4	240#
		6'	WSJ360-100-8-6	250	356#	103-3/4	9-3/4	6-5/8	69-1/8	5	4-1/4	6	-	-	1-1/2	4	420#
		8'	WSJ360-100-8-8	250	390#	108-1/4	9-3/4	6-5/8	73-7/8	5	9	6	-	-	1-1/2	4	615#
		10'	WSJ360-100-8-10	250	411#	108-1/4	9-3/4	6-5/8	73-7/8	5	9	6	-	-	1-1/2	4	822#
		12'	WSJ360-100-8-12	250	443#	111-1/4	12-3/4	6-5/8	64-7/8	5	12	6	-	-	1-1/2	4	1,047#
		14'	WSJ360-100-8-14	250	465#	111-1/4	12-3/4	6-5/8	64-7/8	5	12	6	-	-	1-1/2	4	1,289#
	16'	WSJ360-100-8-16	250	488#	111-1/4	12-3/4	6-5/8	64-7/8	5	12	6	-	-	1-1/2	4	1,547#	
	10'	4'	WSJ360-100-10-4	250	378#	127-3/4	9-3/4	6-5/8	93-1/8	5	4-1/4	6	-	-	1-1/2	4	240#
		6'	WSJ360-100-10-6	250	394#	127-3/4	9-3/4	6-5/8	93-1/8	5	4-1/4	6	-	-	1-1/2	4	420#
		8'	WSJ360-100-10-8	250	427#	132-1/4	9-3/4	6-5/8	97-7/8	5	9	6	-	-	1-1/2	4	615#
		10'	WSJ360-100-10-10	250	448#	132-1/4	9-3/4	6-5/8	97-7/8	5	9	6	-	-	1-1/2	4	822#
		12'	WSJ360-100-10-12	250	481#	135-1/4	12-3/4	6-5/8	88-7/8	5	12	6	-	-	1-1/2	4	1,047#
		14'	WSJ360-100-10-14	250	503#	135-1/4	12-3/4	6-5/8	88-7/8	5	12	6	-	-	1-1/2	4	1,289#
	16'	WSJ360-100-10-16	250	525#	135-1/4	12-3/4	6-5/8	88-7/8	5	12	6	-	-	1-1/2	4	1,547#	
	12'	4'	WSJ360-100-12-4	250	415#	151-3/4	9-3/4	6-5/8	117-1/8	5	4-1/4	6	-	-	1-1/2	4	240#
		6'	WSJ360-100-12-6	250	432#	151-3/4	9-3/4	6-5/8	117-1/8	5	4-1/4	6	-	-	1-1/2	4	420#
		8'	WSJ360-100-12-8	250	465#	156-1/4	9-3/4	6-5/8	121-7/8	5	9	6	-	-	1-1/2	4	615#
		10'	WSJ360-100-12-10	250	486#	156-1/4	9-3/4	6-5/8	121-7/8	5	9	6	-	-	1-1/2	4	822#
		12'	WSJ360-100-12-12	250	519#	159-1/4	12-3/4	6-5/8	112-7/8	5	12	6	-	-	1-1/2	4	1,047#
		14'	WSJ360-100-12-14	250	541#	159-1/4	12-3/4	6-5/8	112-7/8	5	12	6	-	-	1-1/2	4	1,289#
	16'	WSJ360-100-12-16	250	606#	159-1/4	12-3/4	8-5/8	112-7/8	5	12	6	-	-	1-1/2	4	1,547#	
	14'	4'	WSJ360-100-14-4	250	437#	175-3/4	9-3/4	6-5/8	141-1/8	5	4-1/4	6	-	-	1-1/2	4	240#
		6'	WSJ360-100-14-6	250	447#	175-3/4	9-3/4	6-5/8	141-1/8	5	4-1/4	6	-	-	1-1/2	4	420#
		8'	WSJ360-100-14-8	250	480#	180-1/4	9-3/4	6-5/8	145-7/8	5	9	6	-	-	1-1/2	4	615#
10'		WSJ360-100-14-10	250	501#	180-1/4	9-3/4	6-5/8	145-7/8	5	9	6	-	-	1-1/2	4	822#	
12'		WSJ360-100-14-12	250	539#	183-1/4	12-3/4	8-5/8	136-7/8	5	12	6	-	-	1-1/2	4	1,047#	
14'		WSJ360-100-14-14	250	556#	183-1/4	12-3/4	8-5/8	136-7/8	5	12	6	-	-	1-1/2	4	1,289#	
16'	WSJ360-100-14-16	250	621#	183-1/4	12-3/4	8-5/8	136-7/8	5	12	6	-	-	1-1/2	4	1,547#		
<b>150#</b>	8'	4'	WSJ360-150-8-4	250	340#	103-3/4	9-3/4	6-5/8	69-1/8	5	4-1/4	6	-	-	1-1/2	4	348#
		6'	WSJ360-150-8-6	250	356#	103-3/4	9-3/4	6-5/8	69-1/8	5	4-1/4	6	-	-	1-1/2	4	595#
		8'	WSJ360-150-8-8	250	390#	108-1/4	9-3/4	6-5/8	73-7/8	5	9	6	-	-	1-1/2	4	857#
		10'	WSJ360-150-8-10	250	411#	108-1/4	9-3/4	6-5/8	73-7/8	5	9	6	-	-	1-1/2	4	1,137#
		12'	WSJ360-150-8-12	250	443#	111-1/4	12-3/4	6-5/8	64-7/8	5	12	6	-	-	1-1/2	4	1,432#
		14'	WSJ360-150-8-14	500	511#	113-3/4	16-1/4	6-5/8	55-7/8	7-1/8	15	6	-	-	2-7/8	4	1,873#
	16'	WSJ360-150-8-16	500	589#	113-3/4	16-1/4	8-5/8	55-7/8	7-1/8	15	6	-	-	2-7/8	4	2,242#	
	10'	4'	WSJ360-150-10-4	250	378#	127-3/4	9-3/4	6-5/8	93-1/8	5	4-1/4	6	-	-	1-1/2	4	348#
		6'	WSJ360-150-10-6	250	394#	127-3/4	9-3/4	6-5/8	93-1/8	5	4-1/4	6	-	-	1-1/2	4	595#
		8'	WSJ360-150-10-8	250	427#	132-1/4	9-3/4	6-5/8	97-7/8	5	9	6	-	-	1-1/2	4	857#
		10'	WSJ360-150-10-10	250	448#	132-1/4	9-3/4	6-5/8	97-7/8	5	9	6	-	-	1-1/2	4	1,137#
		12'	WSJ360-150-10-12	250	487#	135-1/4	12-3/4	6-5/8	88-7/8	5	12	6	-	-	1-1/2	4	1,432#
		14'	WSJ360-150-10-14	500	549#	137-3/4	16-1/4	6-5/8	79-7/8	7-1/8	15	6	-	-	2-7/8	4	1,873#
	16'	WSJ360-150-10-16	500	634#	137-3/4	16-1/4	8-5/8	79-7/8	7-1/8	15	6	-	-	2-7/8	4	2,242#	
	12'	4'	WSJ360-150-12-4	250	415#	151-3/4	9-3/4	6-5/8	117-1/8	5	4-1/4	6	-	-	1-1/2	4	348#
		6'	WSJ360-150-12-6	250	432#	151-3/4	9-3/4	6-5/8	117-1/8	5	4-1/4	6	-	-	1-1/2	4	595#
		8'	WSJ360-150-12-8	250	465#	156-1/4	9-3/4	6-5/8	121-7/8	5	9	6	-	-	1-1/2	4	857#
		10'	WSJ360-150-12-10	250	486#	156-1/4	9-3/4	6-5/8	121-7/8	5	9	6	-	-	1-1/2	4	1,137#
		12'	WSJ360-150-12-12	250	519#	159-1/4	12-3/4	6-5/8	112-7/8	5	12	6	-	-	1-1/2	4	1,432#
		14'	WSJ360-150-12-14	500	630#	161-3/4	16-1/4	8-5/8	103-7/8	7-1/8	15	6	-	-	2-7/8	4	1,873#
	16'	WSJ360-150-12-16	500	679#	161-3/4	16-1/4	8-5/8	103-7/8	7-1/8	15	6	-	-	2-7/8	4	2,242#	
	14'	6'	WSJ360-150-14-6	250	492#	175-3/4	9-3/4	8-5/8	141-1/8	5	4-1/4	6	-	-	1-1/2	4	348#
		8'	WSJ360-150-14-8	250	525#	180-1/4	9-3/4	8-5/8	145-7/8	5	9	6	-	-	1-1/2	4	595#
		10'	WSJ360-150-14-10	250	546#	180-1/4	9-3/4	8-5/8	145-7/8	5	9	6	-	-	1-1/2	4	857#
12'		WSJ360-150-14-12	250	679#	183-1/4	12-3/4	8-5/8	136-7/8	5	12	6	-	-	1-1/2	4	1,137#	
14'		WSJ360-150-14-14	500	690#	185-3/4	16-1/4	8-5/8	127-7/8	7-1/8	15	6	-	-	2-7/8	4	1,432#	
16'		WSJ360-150-14-16	500	739#	185-3/4	16-1/4	8-5/8	127-7/8	7-1/8	15	6	-	-	2-7/8	4	2,242#	
<b>250#</b>	8'	4'	WSJ360-250-8-4	250	340#	103-3/4	9-3/4	6-5/8	69-1/8	5	4-1/4	6	-	-	1-1/2	4	558#
		6'	WSJ360-250-8-6	250	367#	108-1/4	9-3/4	6-5/8	73-7/8	5	9	6	-	-	1-1/2	4	945#
		8'	WSJ360-250-8-8	250	461#	108-1/4	9-3/4	6-5/8	73-7/8	5	9	6	-	-	1-1/2	4	1,347#
		10'	WSJ360-250-8-10	250	499#	111-1/4	12-3/4	6-5/8	64-7/8	5	12	6	-	-	1-1/2	4	1,767#
		12'	WSJ360-250-8-12	500	562#	114-1/4	12-3/4	8-5/8	55-7/8	7-1/8	15	36	10	20	2-7/8	6	955#
		14'	WSJ360-250-8-14	500	613#	113-3/4	16-1/4	8-5/8	55-7/8	7-1/8	15	36	10	20	2-7/8	6	1,186#
	16'	WSJ360-250-8-16	500	661#	113-3/4	16-1/4	8-5/8	55-7/8	7-1/8	15	36	10	20	2-7/8	6	1,410#	
	10'	4'	WSJ360-250-10-4	250	378#	127-3/4	9-3/4	6-5/8	93-1/8	5	4-1/4	6	-	-	1-1/2	4	558#
		6'	WSJ360-250-10-6	250	405#	132-1/4	9-3/4	6-5/8	97-7/8	5	9	6	-	-	1-1/2	4	945#
		8'	WSJ360-250-10-8	250	535#	132-1/4	9-3/4	8-5/8	97-7/8	5	9	6	-	-	1-1/2	4	1,347#
		10'	WSJ360-250-10-10	250	574#	135-1/4	12-3/4	8-5/8	88-7/8	5	12	6	-	-	1-1/2	4	1,767#
		12'	WSJ360-250-10-12	500	607#	138-1/4	15-3/4	8-5/8	79-7/8	7-1/8	15	36	10	20	2-7/8	6	955#
14'		WSJ360-250-10-14	500	658#	137-3/4	16-1/4	8-5/8	79-7/8	7-1/8	15	36	10	20	2-7/8	6	1,186#	
16'	WSJ360-250-10-16	500	706#	137-3/4	16-1/4	8-5/8	79-7/8	7-1/8	15	36	10	20	2-7/8	6	1,410#		

Note: Dimensions are for reference only and are subject to change without notice.

**WSJ360 FREE STANDING WORK STATION JIB CRANES: 360° ROTATION**

CAPACITY	HUB	SPAN	MODEL NUMBER	TRACK SERIES	WEIGHT	C	D	E	F	G	H	L	S1	S2	T	BOLT QTY.	ANCHOR BOLT LOAD	
						in	in	in	in	in	in	in	in	in	in			
250#	12'	4'	WSJ360-250-12-4	250	415#	151-3/4	9-3/4	6-5/8	117-1/8	5	4-1/4	6	-	-	1-1/2	4	558#	
		6'	WSJ360-250-12-6	250	443#	156-1/4	9-3/4	6-5/8	121-7/8	5	9	6	-	-	1-1/2	4	945#	
		8'	WSJ360-250-12-8	250	580#	156-1/4	9-3/4	8-5/8	121-7/8	5	9	6	-	-	1-1/2	4	1,347#	
		10'	WSJ360-250-12-10	250	618#	159-1/4	12-3/4	8-5/8	112-7/8	5	12	6	-	-	1-1/2	4	1,767#	
		12'	WSJ360-250-12-12	500	651#	162-1/4	15-3/4	8-5/8	103-7/8	7-1/8	15	36	10	20	2-7/8	6	955#	
		14'	WSJ360-250-12-14	500	702#	161-3/4	16-1/4	8-5/8	103-7/8	7-1/8	15	36	10	20	2-7/8	6	1,186#	
	16'	WSJ360-250-12-16	500	891#	161-3/4	16-1/4	12-3/4	103-7/8	7-1/8	15	36	8-1/2	20	2-7/8	6	1,410#		
	14'	4'	WSJ360-250-14-4	250	647#	175-3/4	9-3/4	8-5/8	141-1/8	5	4-1/4	6	-	-	1-1/2	4	558#	
		6'	WSJ360-250-14-6	250	675#	180-1/4	9-3/4	8-5/8	145-7/8	5	9	6	-	-	1-1/2	4	945#	
		8'	WSJ360-250-14-8	250	712#	180-1/4	9-3/4	8-5/8	145-7/8	5	9	6	-	-	1-1/2	4	1,347#	
		10'	WSJ360-250-14-10	250	750#	183-1/4	12-3/4	8-5/8	136-7/8	5	12	6	-	-	1-1/2	4	1,767#	
		12'	WSJ360-250-14-12	500	783#	186-1/4	15-3/4	12-3/4	127-7/8	7-1/8	15	36	8-1/2	20	2-7/8	6	955#	
		14'	WSJ360-250-14-14	500	834#	185-3/4	16-1/4	12-3/4	127-7/8	7-1/8	15	36	8-1/2	20	2-7/8	6	1,186#	
	16'	WSJ360-250-14-16	500	857#	185-3/4	16-1/4	12-3/4	127-7/8	7-1/8	15	36	8-1/2	20	2-7/8	6	1,410#		
	500#	8'	4'	WSJ360-500-8-4	500	380#	108-1/4	9-3/4	8-5/8	73-7/8	7-1/8	9	6	-	-	2-7/8	4	1,088#
			6'	WSJ360-500-8-6	500	405#	108-1/4	9-3/4	8-5/8	73-7/8	7-1/8	9	6	-	-	2-7/8	4	1,831#
			8'	WSJ360-500-8-8	500	518#	111-1/4	12-3/4	8-5/8	64-7/8	7-1/8	12	36	10	20	2-7/8	6	1,071#
			10'	WSJ360-500-8-10	500	640#	111-1/4	12-5/8	12-3/4	64-7/8	7-1/8	12	36	8-1/2	20	2-7/8	6	1,417#
12'			WSJ360-500-8-12	500	676#	114-1/4	15-5/8	12-3/4	55-7/8	7-1/8	15	36	8-1/2	20	2-7/8	6	1,771#	
14'			WSJ360-500-8-14	1000	1,058#	116-1/4	16-1/4	12-3/4	58-3/8	7-7/8	17-1/2	48	8-1/2	20	3-1/8	6	2,201#	
16'		WSJ360-500-8-16	1000	1,107#	116-1/4	16-1/4	12-3/4	58-3/8	7-7/8	17-1/2	48	8-1/2	20	3-1/8	6	2,594#		
10'		4'	WSJ360-500-10-4	500	425#	132-1/4	9-3/4	8-5/8	97-7/8	7-1/8	9	6	-	-	2-7/8	4	1,088#	
		6'	WSJ360-500-10-6	500	450#	132-1/4	9-3/4	8-5/8	97-7/8	7-1/8	9	6	-	-	2-7/8	4	1,831#	
		8'	WSJ360-500-10-8	500	563#	135-1/4	12-3/4	8-5/8	88-7/8	7-1/8	12	36	10	20	2-7/8	6	1,071#	
		10'	WSJ360-500-10-10	500	707#	135-1/4	12-5/8	12-3/4	88-7/8	7-1/8	12	36	8-1/2	20	2-7/8	6	1,417#	
		12'	WSJ360-500-10-12	500	743#	138-1/4	15-5/8	12-3/4	79-7/8	7-1/8	15	36	8-1/2	20	2-7/8	6	1,771#	
		14'	WSJ360-500-10-14	1000	1,127#	140-1/4	16-1/4	12-3/4	82-3/8	7-7/8	17-1/2	48	8-1/2	20	3-1/8	6	2,201#	
16'		WSJ360-500-10-16	1000	1,176#	140-1/4	16-1/4	12-3/4	82-3/8	7-7/8	17-1/2	48	8-1/2	20	3-1/8	6	2,594#		
12'		4'	WSJ360-500-12-4	500	469#	156-1/4	9-3/4	8-5/8	121-7/8	7-1/8	9	6	-	-	2-7/8	4	1,088#	
		6'	WSJ360-500-12-6	500	494#	156-1/4	9-3/4	8-5/8	121-7/8	7-1/8	9	6	-	-	2-7/8	4	1,831#	
		8'	WSJ360-500-12-8	500	749#	159-1/4	12-5/8	12-3/4	112-7/8	7-1/8	12	36	8-1/2	20	2-7/8	6	1,071#	
		10'	WSJ360-500-12-10	500	773#	159-1/4	12-5/8	12-3/4	112-7/8	7-1/8	12	36	8-1/2	20	2-7/8	6	1,417#	
		12'	WSJ360-500-12-12	500	810#	162-1/4	15-5/8	12-3/4	103-7/8	7-1/8	15	36	8-1/2	20	2-7/8	6	1,771#	
		14'	WSJ360-500-12-14	1000	1,227#	164-1/4	16-1/4	12-3/4	106-3/8	7-7/8	17-1/2	48	8-1/2	20	3-1/8	6	2,201#	
16'		WSJ360-500-12-16	1000	1,276#	165-1/4	16-5/8	14	106-3/8	7-7/8	17-1/2	48	11	22	3-1/8	6	2,038#		
14'		4'	WSJ360-500-14-4	500	855#	180-1/4	9-5/8	12-3/4	145-7/8	7-1/8	9	36	8-1/2	20	2-7/8	6	407#	
		6'	WSJ360-500-14-6	500	879#	180-1/4	9-5/8	12-3/4	145-7/8	7-1/8	9	36	8-1/2	20	2-7/8	6	735#	
		8'	WSJ360-500-14-8	500	900#	183-1/4	12-5/8	12-3/4	136-7/8	7-1/8	12	36	8-1/2	20	2-7/8	6	1,072#	
	10'	WSJ360-500-14-10	500	912#	183-1/4	12-5/8	12-3/4	136-7/8	7-1/8	12	36	8-1/2	20	2-7/8	6	1,417#		
	12'	WSJ360-500-14-12	500	939#	186-1/4	15-5/8	12-3/4	127-7/8	7-1/8	15	36	8-1/2	20	2-7/8	6	1,772#		
	14'	WSJ360-500-14-14	1000	1,306#	188-1/4	16-1/4	12-3/4	130-3/8	7-7/8	17-1/2	48	8-1/2	20	3-1/8	6	2,201#		
16'	WSJ360-500-14-16	1000	1,355#	189-1/4	16-5/8	14	130-3/8	7-7/8	17-1/2	48	11	22	3-1/8	6	2,038#			
1000#	8'	4'	WSJ360-1000-8-4	1000	556#	108-1/4	9-5/8	12-3/4	73-7/8	7-7/8	9	48	8-1/2	20	3-1/8	6	797#	
		6'	WSJ360-1000-8-6	1000	585#	108-1/4	9-5/8	12-3/4	73-7/8	7-7/8	9	48	8-1/2	20	3-1/8	6	1,434#	
		8'	WSJ360-1000-8-8	1000	631#	111-1/4	12-5/8	12-3/4	64-7/8	7-7/8	12	48	8-1/2	20	3-1/8	6	2,083#	
		10'	WSJ360-1000-8-10	1000	702#	114-1/4	15-5/8	12-3/4	56-7/8	7-7/8	15	48	8-1/2	20	3-1/8	6	2,739#	
		12'	WSJ360-1000-8-12	1000	728#	116-1/4	15-5/8	12-3/4	57-7/8	7-7/8	17	48	8-1/2	20	3-1/8	6	3,405#	
		14'	WSJ360-1000-8-14	2000	1,214#	118-3/4	18-5/8	14	40	8-1/8	20	48	11	22	2-7/8	6	3,320#	
	16'	WSJ360-1000-8-16	2000	1,279#	118-3/4	18-5/8	14	40	8-1/8	20	48	11	22	2-7/8	6	3,907#		
	10'	4'	WSJ360-1000-10-4	1000	622#	132-1/4	9-5/8	12-3/4	97-7/8	7-7/8	9	48	8-1/2	20	3-1/8	6	797#	
		6'	WSJ360-1000-10-6	1000	652#	132-1/4	9-5/8	12-3/4	97-7/8	7-7/8	9	48	8-1/2	20	3-1/8	6	1,434#	
		8'	WSJ360-1000-10-8	1000	698#	135-1/4	12-5/8	12-3/4	88-7/8	7-7/8	12	48	8-1/2	20	3-1/8	6	2,083#	
		10'	WSJ360-1000-10-10	1000	768#	138-1/4	15-5/8	12-3/4	80-7/8	7-7/8	15	48	8-1/2	20	3-1/8	6	2,739#	
		12'	WSJ360-1000-10-12	1000	795#	140-1/4	15-5/8	12-3/4	81-7/8	7-7/8	17	48	8-1/2	20	3-1/8	6	3,405#	
		14'	WSJ360-1000-10-14	2000	1,283#	142-3/4	18-5/8	14	64	8-1/8	20	48	11	22	2-7/8	6	3,320#	
	16'	WSJ360-1000-10-16	2000	1,348#	142-3/4	18-5/8	14	64	8-1/8	20	48	11	22	2-7/8	6	3,907#		
	12'	4'	WSJ360-1000-12-4	1000	689#	156-1/4	9-5/8	12-3/4	121-7/8	7-7/8	9	48	8-1/2	20	3-1/8	6	797#	
		6'	WSJ360-1000-12-6	1000	719#	156-1/4	9-5/8	12-3/4	121-7/8	7-7/8	9	48	8-1/2	20	3-1/8	6	1,434#	
		8'	WSJ360-1000-12-8	1000	765#	159-1/4	12-5/8	12-3/4	112-7/8	7-7/8	12	48	8-1/2	20	3-1/8	6	2,083#	
		10'	WSJ360-1000-12-10	1000	835#	162-1/4	15-5/8	12-3/4	104-7/8	7-7/8	15	48	8-1/2	20	3-1/8	6	2,739#	
		12'	WSJ360-1000-12-12	1000	862#	164-1/4	15-5/8	12-3/4	105-7/8	7-7/8	17	48	8-1/2	20	3-1/8	6	3,405#	
		14'	WSJ360-1000-12-14	2000	1,383#	166-3/4	18-5/8	14	88	8-1/8	20	48	11	22	2-7/8	6	3,320#	
	16'	WSJ360-1000-12-16	2000	1,448#	166-3/4	18-5/8	16	88	8-1/8	20	48	13	26	2-7/8	12	1,597#		
	14'	4'	WSJ360-1000-14-4	1000	1,193#	180-1/4	9-5/8	12-3/4	145-7/8	7-7/8	9	48	8-1/2	20	3-1/8	6	797#	
		6'	WSJ360-1000-14-6	1000	1,204#	180-1/4	9-5/8	12-3/4	145-7/8	7-7/8	9	48	8-1/2	20	3-1/8	6	1,441#	
		8'	WSJ360-1000-14-8	1000	1,228#	184-1/4	13	14	136-7/8	7-7/8	12	48	11	22	3-1/8	6	1,611#	
10'		WSJ360-1000-14-10	1000	1,254#	187-1/4	16	14	128-7/8	7-7/8	15	48	11	22	3-1/8				

**WSJ200 WALL CANTILEVER WORK STATION JIB CRANES: 200° ROTATION**

CAPACITY	SPAN	MODEL NUMBER	TRACK SERIES	WEIGHT	B	G	H	T	THRUST & PULL
					in	in	in	in	
100#	4'	WSJ200-100-4	250	110#	36	5	4-1/4	1-1/2	185#
	6'	WSJ200-100-6	250	127#	36	5	4-1/4	1-1/2	306#
	8'	WSJ200-100-8	250	160#	36	5	9	1-1/2	437#
	10'	WSJ200-100-10	250	181#	36	5	9	1-1/2	579#
	12'	WSJ200-100-12	250	216#	48	5	12	1-1/2	549#
	14'	WSJ200-100-14	250	236#	48	5	12	1-1/2	672#
	16'	WSJ200-100-16	250	258#	48	5	12	1-1/2	803#
150#	4'	WSJ200-150-4	250	110#	36	5	4-1/4	1-1/2	267#
	6'	WSJ200-150-6	250	127#	36	5	4-1/4	1-1/2	434#
	8'	WSJ200-150-8	250	160#	36	5	9	1-1/2	612#
	10'	WSJ200-150-10	250	181#	36	5	9	1-1/2	801#
	12'	WSJ200-150-12	250	216#	48	5	12	1-1/2	750#
	14'	WSJ200-150-14	500	282#	60	7-1/8	15	2-7/8	782#
	16'	WSJ200-150-16	500	330#	60	7-1/8	15	2-7/8	932#
250#	4'	WSJ200-250-4	250	110#	36	5	4-1/4	1-1/2	430#
	6'	WSJ200-250-6	250	138#	36	5	9	1-1/2	691#
	8'	WSJ200-250-8	250	160#	36	5	9	1-1/2	962#
	10'	WSJ200-250-10	250	198#	48	5	12	1-1/2	933#
	12'	WSJ200-250-12	500	252#	60	7-1/8	15	2-7/8	945#
	14'	WSJ200-250-14	500	282#	60	7-1/8	15	2-7/8	1,160#
	16'	WSJ200-250-16	500	330#	60	7-1/8	15	2-7/8	1,366#
500#	4'	WSJ200-500-4	500	121#	36	7-1/8	9	2-7/8	843#
	6'	WSJ200-500-6	500	146#	36	7-1/8	9	2-7/8	1,342#
	8'	WSJ200-500-8	500	188#	48	7-1/8	12	2-7/8	1,390#
	10'	WSJ200-500-10	500	213#	48	7-1/8	12	2-7/8	1,784#
	12'	WSJ200-500-12	500	262#	60	7-1/8	15	2-7/8	1,750#
	14'	WSJ200-500-14	1000	384#	60	7-7/8	17-1/2	3-1/8	2,152#
	16'	WSJ200-500-16	1000	416#	60	7-7/8	17-1/2	3-1/8	2,512#
1000#	4'	WSJ200-1000-4	1000	128#	36	7-7/8	9	3-1/8	1,666#
	6'	WSJ200-1000-6	1000	158#	36	7-7/8	9	3-1/8	2,639#
	8'	WSJ200-1000-8	1000	204#	48	7-7/8	12	3-1/8	2,722#
	10'	WSJ200-1000-10	1000	274#	60	7-7/8	15	3-1/8	2,781#
	12'	WSJ200-1000-12	1000	301#	60	7-7/8	17	3-1/8	3,394#
	14'	WSJ200-1000-14	2000	546#	72	8-1/8	20	2-7/8	3,451#
	16'	WSJ200-1000-16	2000	595#	72	8-1/8	20	2-7/8	4,010#

Note: Dimensions are for reference only and are subject to change without notice.

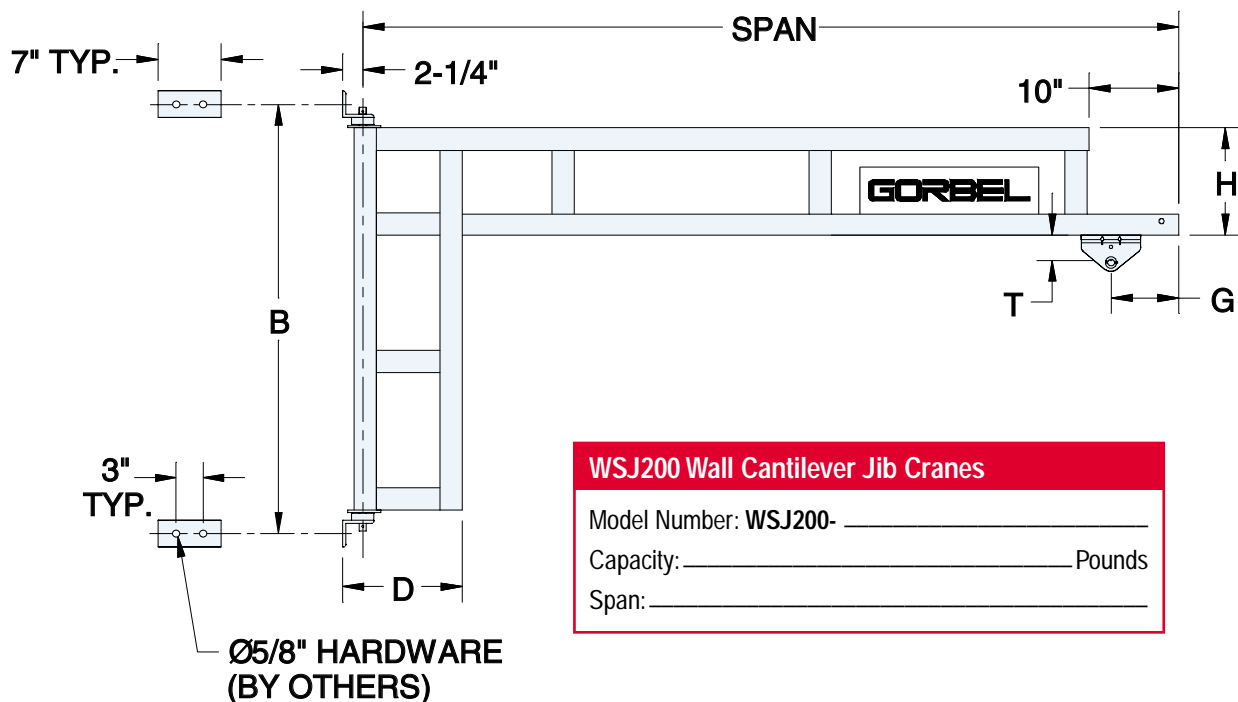



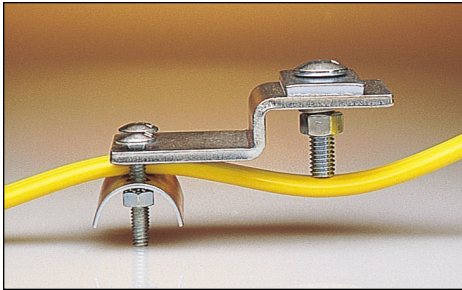

*Festoon Clamp*



*Festoon Glider*

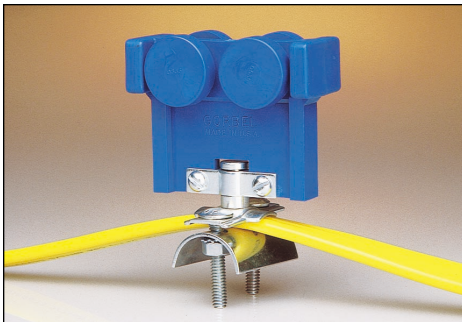

*Festoon Trolley*

## Optional Accessories

### Festoon Clamps

Festoon clamps anchor the festooning at the start of the jib boom. They also prevent the festoon gliders from exiting the track and they can provide a redundant stop for the trolley. Festoon clamps for vacuum hose are also available (not shown).

### Festoon Gliders

Festoon gliders are used to support flat electrical cable along the jib boom. No tools are required to attach the festooning to the gliders. One festoon clamp is required with the use of festoon gliders. Not available for AL100 jibs.

### Festoon Trolleys

Gorbel festoon trolleys are used to support flat cable, air hose or round cable along the jib boom. The trolleys have four wheels and a pivoting festoon saddle support. Festoon trolleys for vacuum hose are also available (not shown). One festoon clamp is required with the use of festoon trolleys.

### Flat Cable and/or Air Hose

A flat cable festooning system is required when using an electric powered lifting device. Air hose is also available and is supported by festoon trolleys.

### Four Ring Electrical Collector (Top or Bottom Entry)

A collector is needed to provide a continuous 360° boom rotation when using an electric powered lifting device. A bottom entry collector requires four (4) additional inches of clearance above the pivot pin. A top entry collector requires 11-1/4 additional inches of clearance above the pivot pin.

### Air Swivel (Top or Bottom Entry)

An air swivel is needed to provide a continuous 360° boom rotation when using an air powered lifting device. A bottom entry air swivel requires an additional five (5) inches of clearance above the pivot pin. A top entry air swivel requires between 8-1/2 to 9-1/2 inches (depending on span and capacity) of additional clearance above the pivot pin.

### Manual Rotation Stops

To limit the WSJ360 rotation to less than 360° to prevent boom damage to machines, equipment or building structures, rotation stops are required.

### WSJ360 Portable Base

To allow a WSJ360 to be lifted with a lift truck and transported to multiple locations, a portable base is required.

### Vacuum Platform Attachment

If a vacuum lifter motor/blower is required to be mounted on the mast or building column, then a specially-designed vacuum blower support platform attachment can be designed for this specific application.

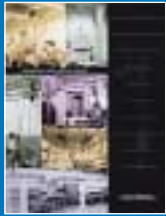

Capabilities



G-Force™



Robotic

### WANT TO KNOW MORE?

Your authorized Gorbel dealer can give you more information on what makes Gorbel ceiling mounted bridge cranes, monorail, and other Gorbel products *A Class Above*.



Free Standing



Ceiling Mounted



Work Station



Articulating



Jib & Gantry Cranes



Seismic Zone IV



Productivity & Safety



Interlock/Transfer



Telescoping



Tractor Drives



Gorbel overhead materials handling systems are made in the USA and sold through an extensive dealer network. Since 1977, Gorbel has been dedicated to providing ergonomic handling solutions.

# GORBEL

A C L A S S A B O V E

600 Fishers Run  
P.O. Box 593  
Fishers, NY 14453-0593 USA  
800-821-0086  
800-828-1808 Fax

E-mail: [info@gorbel.com](mailto:info@gorbel.com)  
Internet: <http://www.gorbel.com>